

TIE4203 Decision Analysis in Industrial & Operations Management Tutorial #3

Question 1

P4.4 Dr. Tan follows the rules of actional thought. He is an eminent brain surgeon. One day, he has a patient, Mr. Goh, who is unconscious. In considering medical procedures to use for Mr. Goh, he creates the following tree about state-of-the-art medical technology and its impact on patients.

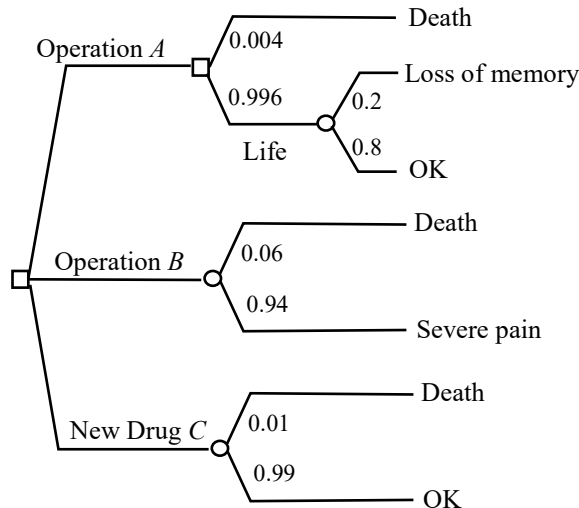

Since Mr. Goh is unconscious, Dr. Tan cannot assess his preference over the possible outcomes. One of the nurses suggests that Dr. Tan use the preference of a typical patient as he sees appropriate from his experience. The preference ordering Dr. Tan lays out is as follows, from the most preferred to the least preferred: OK, Severe pain, Loss of memory, Death. He pulls from his medical records a file on a recent patient in a very similar situation as Mr. Goh; he intends to use this patient's preference in the preliminary analysis for Mr. Goh's case.

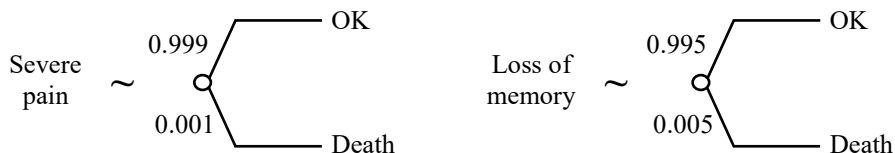

- (a) According to the above information, what is Dr. Tan's best decision?
- (b) Just as Dr. Tan is thinking about how to improve this decision, Mr. Goh regains consciousness. Mr. Goh, who also considers the rules of actional thought as his norm for decision making, starts reviewing Dr. Tan's decision process. He agrees with Dr. Tan's ordering and assessments, except that he feels memory is less valuable to him than Dr. Tan supposed. The following is Mr. Goh's modified preference assessment

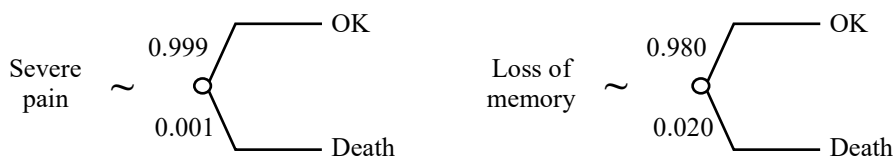

What is Mr. Goh's best decision?

(c) Suppose Mr. Goh gives the following preference probabilities instead of those above.

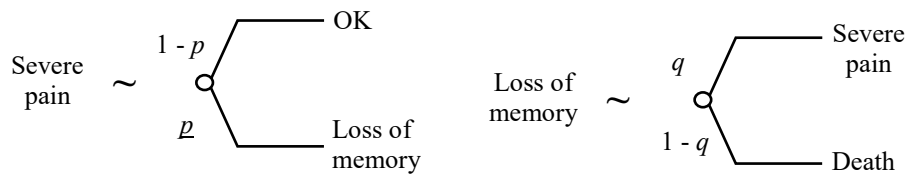

where $p = 0.05$ and $q = 0.981$. Is the above information sufficient for you to recommend a decision? If so, give your recommendation; if not, explain.

Question 2

P4.5 Jeanne who is risk neutral faced the following decision problem where the dollar values are winnings.

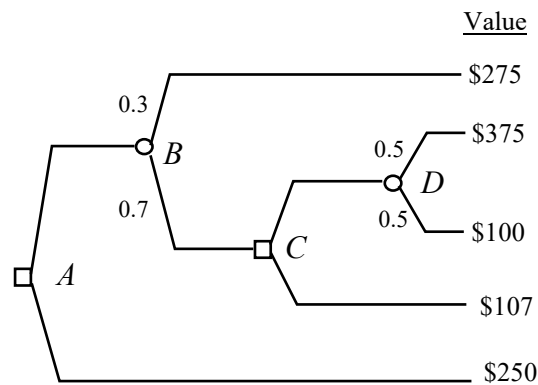

- What is Jeanne certainty equivalent for decision A ?
- What is the most Jeanne should pay for clairvoyance on D before making decision A ?
- What is the most Jeanne should pay for clairvoyance on D that will be available between decisions A and C ?
- What is the most Jeanne should pay for clairvoyance on B before making decision A ?

Question 3

P4.6 Dorothy loves to spend her week-long vacation hiking in Yosemite National Park. But in certain environmental conditions, the streams of the Yosemite Valley are contaminated by an organism that will make her very sick. She can't bring enough water with her to avoid drinking stream water, so if the streams are contaminated, she will certainly get sick.

Dorothy determines that getting sick from contaminated water on a hike is like losing \$2000. Going hiking and not getting sick is worth \$500 to Dorothy. Dorothy is risk neutral.

- (a) Dorothy is considering going on a hiking trip in the winter. She believes that the probability of the streams being contaminated at this time of the year is 0.02. What does she decide? What is her certain equivalent for this choice?
- (b) What is the value of perfect information on the presence of contaminated water?

To reduce the chance of getting sick, Dorothy could go hiking during the warmer seasons, either Spring or Summer. Unfortunately, the park entrance in the Spring costs \$20; however, she feels that the chance that the streams are contaminated is only 0.005. Alternatively, she could wait until the middle of Summer to take her vacation, when the probability of contaminated streams is 0.0001. But Summer is the peak tourist season, and park admission is \$30.

- (c) If she has the opportunity to take either a Spring or a Summer hiking trip, which trip should she take? Assume that she can take only one, not both.
- (d) Regardless of your answer for part (c), assumes she waits until Summer to take her hiking vacation. Right before she leaves, she is offered clairvoyance on contaminated streams. (Her only alternative at that time is to stay home, which is worth \$0.) What is the most she should pay for this information?

Question 4

P4.7 Al, who is risk neutral, faces the following investment decision on stocks *A* and *B* whose performance he believes to be related. If he invests, he must invest in both stocks.

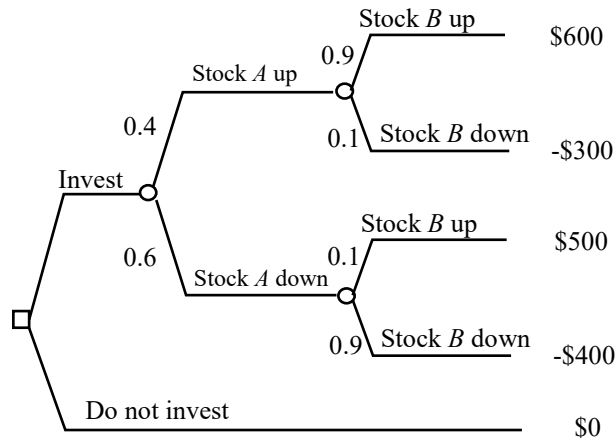

- (a) Find Al's certainty equivalent for the deal.
- (b) Find Al's value of clairvoyance on the performance of Stock *A*.
- (c) Find Al's value of clairvoyance on the performance of Stock *B*.
- (d) Find Al's value of clairvoyance on both the performance of Stocks *A* and *B* together.

Question 5

P4.8 Roy has prostate cancer. He has three alternatives: surgery, chemotherapy and playing a lot of golf. Prostate cancer is a very bad disease, so he will die soon, regardless of what he does. He likes to play golf. If he chooses golf (and has no medical treatment), he will live one year in pain, but be able to enjoy his golf game during that time, then he will die. If he undergoes chemotherapy, he will suffer tremendous nausea for six months and then he will either live for one good year or die right away. If he has prostate surgery he will either live two good years or die on the operating table.

After interviewing his doctor and finding out as well as he can how each of these will feel to him, he decides that he can order these prospects and he assigns the preference probabilities given in the left column.

1.0	Live two good years.
0.9	Live six months nauseated and then one year okay.
0.7	Live one year in pain.
0.2	Live six months nauseated.
0.0	Die now.

He says he wants to make his decision based on the probabilities assigned by his doctor, who says that there is a 60% chance that the surgery will give its better outcome and a 60% chance that chemotherapy will give its better outcome.

- (a) Which alternative should Roy choose?
- (b) If it is possible, calculate the value of perfect information (clairvoyance) on whether the surgery will be a success. If not, explain why and indicate what additional assessment(s) would make it possible to perform this calculation.
- (c) Why might Roy want to know the value of perfect information (clairvoyance)?