

TIE4203 Decision Analysis in Industrial & Operations Management Tutorial #4 (Influence Diagram)

Question 1

P5.1 (Clement and Reilly 2001, Problem 3.9, p99)

A dapper young decision maker has just purchased a new suit for \$200. On the way out the door, he considers taking an umbrella. With the umbrella on hand, the suit will be protected in the event of rain. Without the umbrella, the suit will be ruined if it rains. On the other hand, if it does not rain, carrying the umbrella is an unnecessary inconvenience.

- (a) Draw a decision tree of this situation.
- (b) Draw an influence diagram of the situation.
- (c) Before deciding, the decision maker considers listening to the weather forecast on the radio. Draw an influence diagram that takes into account the weather forecast.

Question 2

P5.2 You are helping a friend who might have cancer. She has just had a needle biopsy taken and will be meeting with her doctor when the laboratory report becomes available to choose a treatment. Her concerns in making the decision is whether she recovers from any cancer and some serious side effects associated with some of the treatment choices. Which of these influence diagrams correctly and best captures her situation?

(a)

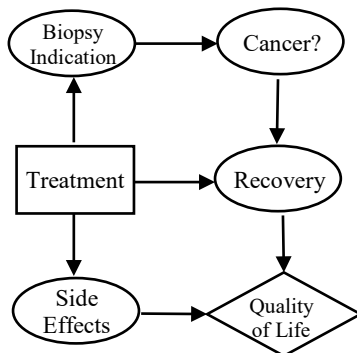

(b)

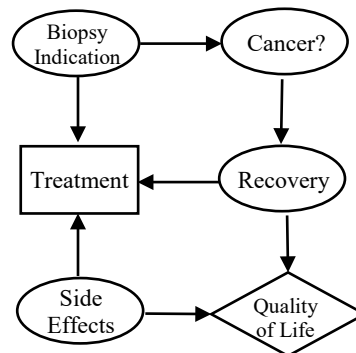

(c)

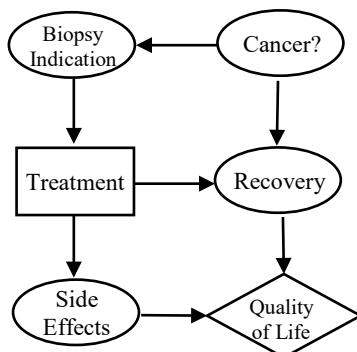

(d)

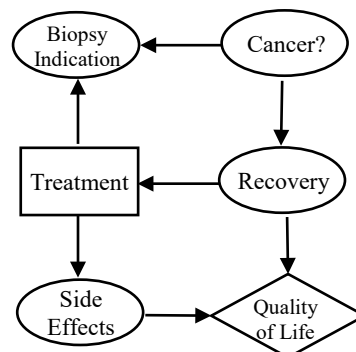

Question 3

P5.4 For each of the influence diagrams below, draw an equivalent decision tree.

(c)

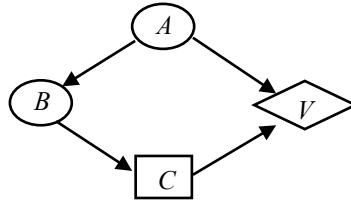

(f)

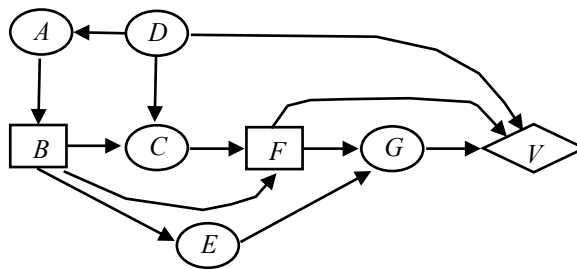

(g)

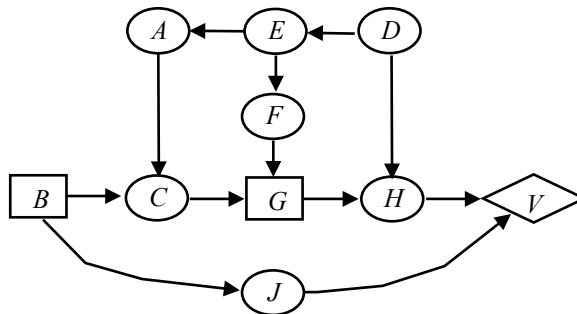

Question 4

P5.5 For each of the following decision trees, draw an equivalent influence diagram representing the decision situation depicted by the tree. Include only those nodes and arcs that are necessary.

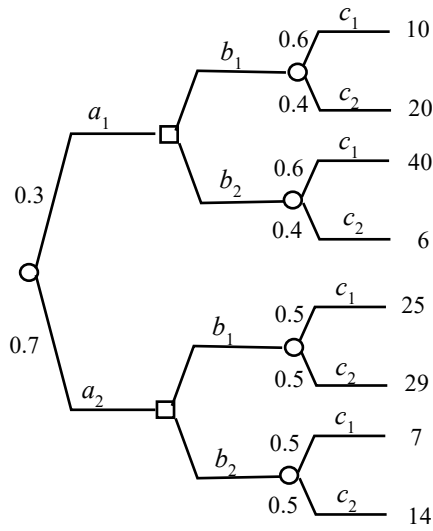

(a)

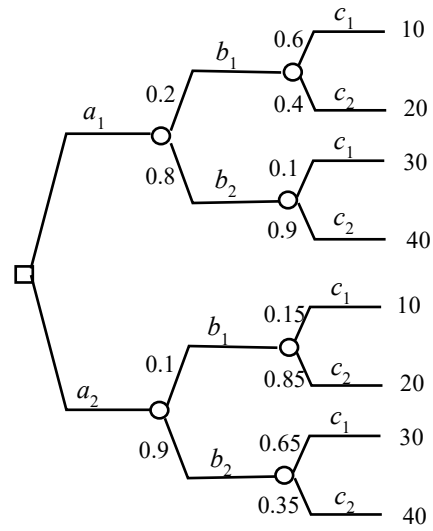

(e)

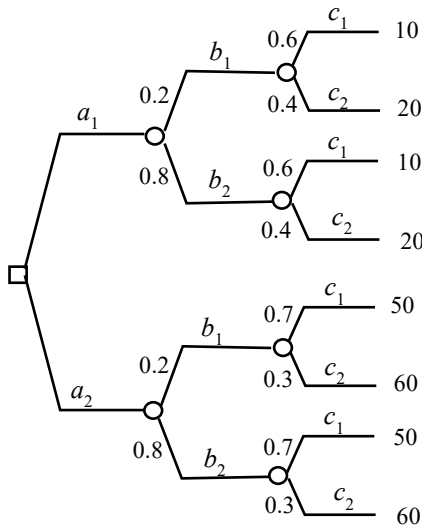

(h)